

Rysunki wymiarowe

WindFree™ Comfort S2 – jednostka wewnętrzna

AR60F09C1AWNEU, AR60F12C1AWNEU

Jednostki: mm [cale]

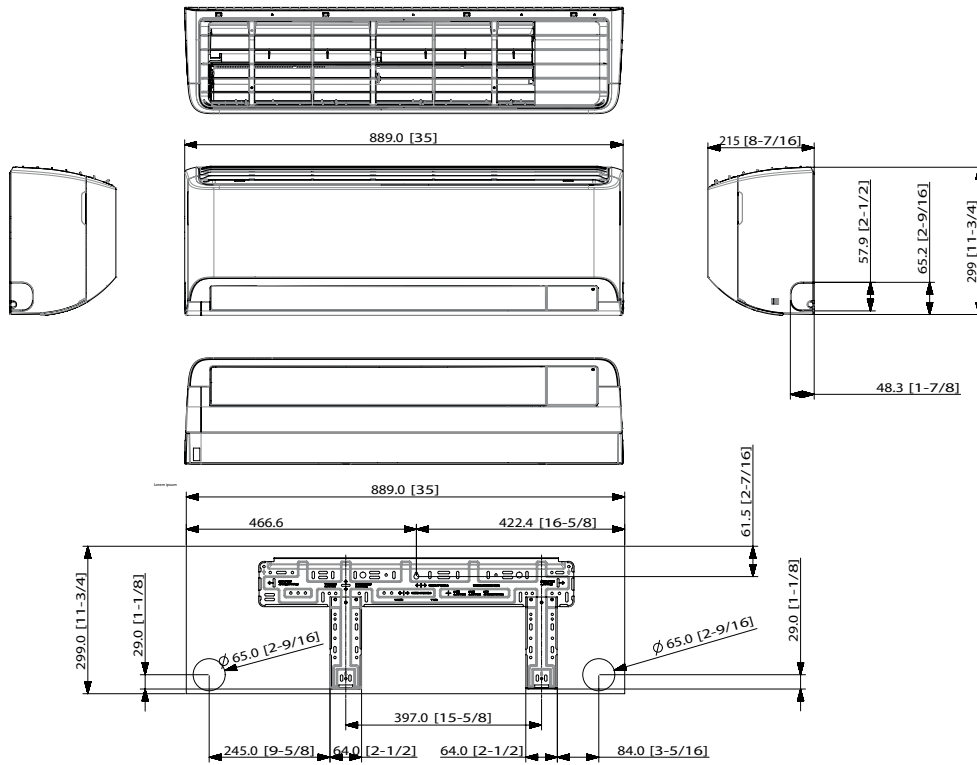

AR60F18/24C1AWNEU

Jednostki: mm [cale]

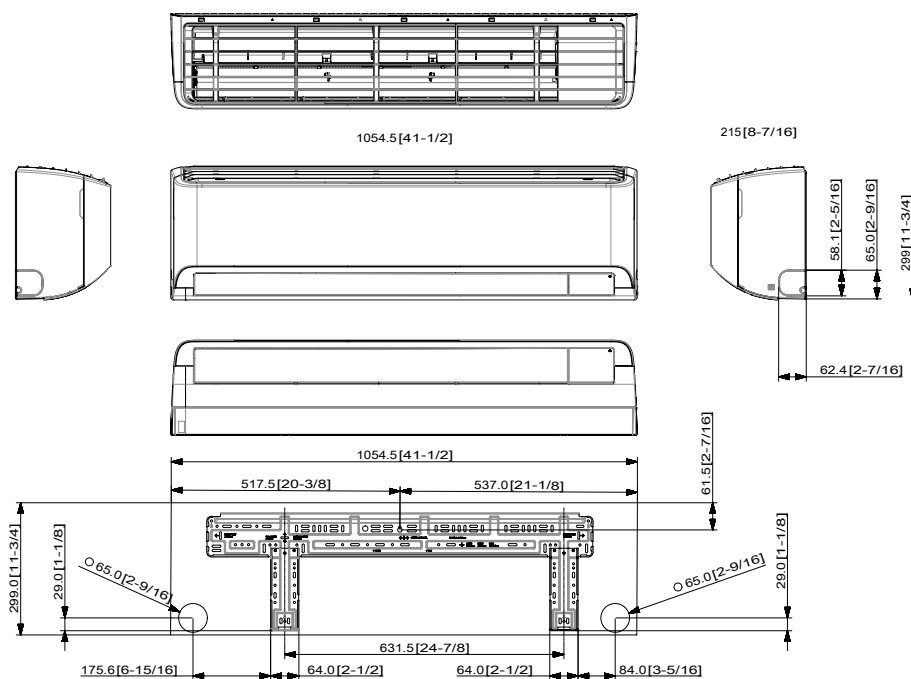

WindFree™ Comfort S2 – jednostka zewnętrzna

AR60F09C1AWXEU, AR60F12C1AWXEU

Jednostki: mm [cal]

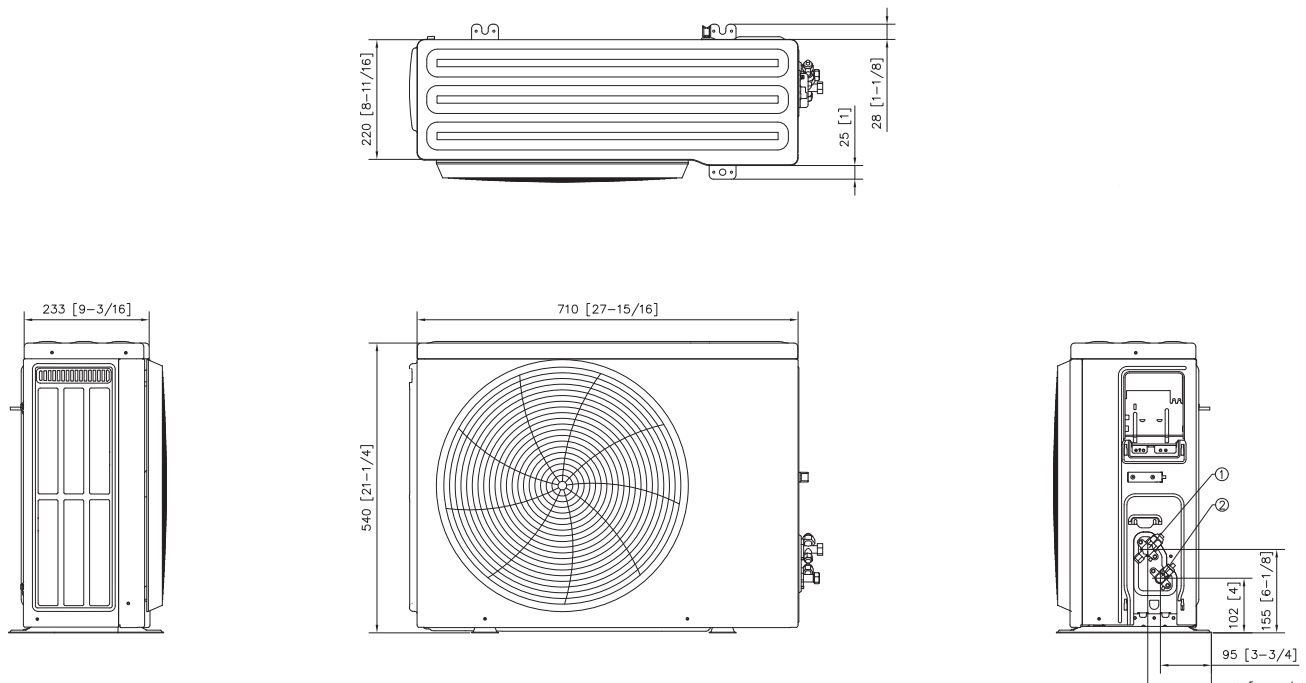

AR60F18/24C1AWXEU

Jednostki: mm [cal]

