

MSZ-RZ R290

Premium Plus Wall Mounted System

Inverter Heat Pump

Mseries

The **MSZ-RZ** range blends low GWP refrigerant, with a high heating performance efficiency in low outdoor temperatures.

With its compact design, quiet operation and enhanced comfort features, the **MSZ-RZ** range is perfect for a wide range of applications.

R290

Key Features & Benefits:

- Utilises a lower GWP refrigerant, reducing environmental impact, supporting sustainability and helping achieve CSR targets
- Provides powerful and efficient heating for consistent comfort and reduced energy costs, even at low ambient conditions
- Integrated refrigeration sensor, providing early detection of leaks and enhancing occupant safety
- Built-in Wi-Fi interface for remote control & monitoring via the Mitsubishi Electric MELCloud app, delivering convenient system management
- Compact design for easy installation, making it ideal for small space.
- Operates with low noise levels to maintain a quiet environment, improving comfort and minimising disturbances
- 3D i-see sensor provides energy efficient, customised comfort by automatically monitoring room occupancy position and body temperatures
- Built in Plasma quad technology neutralises viruses, bacteria, allergens, PM2.5 mould and dust, inhibiting 99.8% of SARS-CoV-2*
- Enhanced comfort with the 'Circulator' mode which automatically circulates the air and eliminates cold spots
- User-friendly backlit controller for remote operation, including scheduling options

* Derived from and subject to test results, for and on behalf of Mitsubishi Electric conducted at the Microbial Testing Laboratory, Textile Quality and Technology Center, Kobe, Japan.



R290



MSZ-RZ INDOOR UNITS		MSZ-RZ25VU	MSZ-RZ35VU
CAPACITY (kW)	Heating (nominal)	3.2 (0.8-5.4)	4.0 (1.1-6.3)
	Cooling (nominal)	2.5 (0.9-3.5)	3.5 (1.0-4.0)
	Heating (UK)	2.62 (0.66-4.43)	3.28 (0.9-5.17)
	Cooling (UK)	2.5 (0.9-3.5)	3.5 (1.0-4.0)
SHF (nominal)		1.00	0.92
COP / EER (nominal)		5.50 / 5.60	4.90 / 4.50
SCOP / SEER (BS EN14825)		5.3 / 11.7	5.2 / 9.6
ErP ENERGY EFFICIENCY CLASS	Heating/Cooling	A+++ / A+++	A+++ / A+++
AIRFLOW (l/s)	Heating - SLo-Lo-Mid-Hi-SHi	85-130-158-195-235	85-130-158-195-255
	Cooling - SLo-Lo-Mid-Hi-SHi	85-108-150-175-195	85-115-150-192-235
PIPE SIZE mm (in)	Gas	9.52 (3/8")	9.52 (3/8")
	Liquid	6.35 (1/4")	6.35 (1/4")
SOUND PRESSURE LEVEL (dBA)	Heating - SLo-Lo-Mid-Hi-SHi	19-25-30-36-41	19-25-30-36-42
	Cooling - SLo-Lo-Mid-Hi-SHi	19-23-29-36-42	19-24-29-36-43
SOUND POWER LEVEL (dBA)		58	59
DIMENSIONS (mm)	Width x Depth x Height	998 x 247 x 305	998 x 247 x 305
WEIGHT (kg)		14.4	14.4
ELECTRICAL SUPPLY		Fed by Outdoor Unit	Fed by Outdoor Unit
FUSE RATING (BS88) - HRC (A)		6	6
INTERCONNECTING CABLE No. CORES		4	4

MUZ-RZ OUTDOOR UNITS		MUZ-RZ25VU	MUZ-RZ35VU
SOUND PRESSURE LEVEL (dBA)	Heating/Cooling	49 / 46	50 / 49
SOUND POWER LEVEL (dBA)	Cooling	60	61
WEIGHT (kg)		37.5	39.5
DIMENSIONS (mm)	Width x Depth x Height	800 x 285 x 714	800 x 285 x 714
ELECTRICAL SUPPLY		220-240v, 50Hz	220-240v, 50Hz
PHASE		Single	Single
SYSTEM POWER INPUT (kW)	Heating/Cooling (nominal)	0.58 / 0.45	0.81 / 0.77
	Heating/Cooling (UK)	0.53 / 0.38	0.74 / 0.65
STARTING CURRENT (A)		2.9	3.8
SYSTEM RUNNING CURRENT (A)	Heating/Cooling [MAX]	2.5 / 2.0 [9.8]	3.5 / 3.3 [9.9]
FUSE RATING (BS88) - HRC (A)		10	10
MAINS CABLE No. CORES		3	3
MAX PIPE LENGTH (m)		20	20
MAX HEIGHT DIFFERENCE (m)		12	12
CHARGE REFRIGERANT (kg) / CO ₂ EQUIVALENT (t) - R290 (GWP 0.02) - 7m		0.39 / 0.0000078	0.39 / 0.0000078
MAX ADDITIONAL REFRIGERANT (kg) / CO ₂ EQUIVALENT (t) - R290 (GWP 0.02)		0.10 / 0.000002	0.10 / 0.000002

MSZ-RZ25/35VU DIMENSIONS

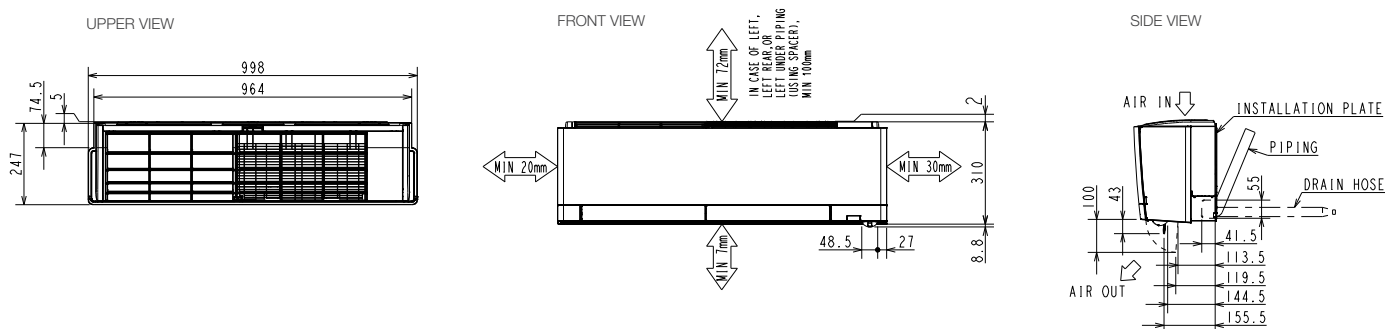

Telephone: 01707 282880
email: air.conditioning@meuk.mee.com
les.mitsubishielectric.co.uk



UNITED KINGDOM Mitsubishi Electric Europe Living Environment Systems Division, Travellers Lane, Hatfield, Hertfordshire, AL10 8XB, England. Telephone: 01707 282880
IRELAND Mitsubishi Electric Europe, Plunkett House, Grange Castle Business Park, Nangor Road, Dublin 22, Ireland. Telephone: (00353) 1 4198800 Email: sales.info@meir.mee.com Web: les.mitsubishielectric.ie

Country of origin: United Kingdom - Italy - Turkey - Japan - Thailand - Malaysia. ©Mitsubishi Electric Europe 2025. Mitsubishi and Mitsubishi Electric are trademarks of Mitsubishi Electric Europe B.V. The company reserves the right to make any variation in technical specification to the equipment described, or to withdraw or replace products without prior notification or public announcement. Mitsubishi Electric is constantly developing and improving its products. All descriptions, illustrations, drawings and specifications in this publication present only general particulars and shall not form part of any contract. All goods are supplied subject to the Company's General Conditions of Sale, a copy of which is available on request. Third-party product and brand names may be trademarks or registered trademarks of their respective owners.

Note: The fuse rating is for guidance only and please refer to the relevant databook for detailed specification. It is the responsibility of a qualified electrician/electrical engineer to select the correct cable size and fuse rating based on current regulation and site specific conditions. Mitsubishi Electric's air conditioning equipment and heat pump systems contain a fluorinated greenhouse gas, R410A (GWP:2088), R32 (GWP:675), R407C (GWP:1774), R134a (GWP:1430), R513A (GWP:631), R454B (GWP:466), R515B (GWP:292), R454C (GWP:148), R1234ze (GWP:7) or R1234yf (GWP:4). *These GWP values are based on Regulation (EU) No 517/2014 from IPCC 4th edition. Mitsubishi Electric's air conditioning equipment and heat pump systems contain a hydrocarbon, R290 (GWP:0.02). *These GWP values are based on IPCC 6th edition.

Effective as of May 2025

