

Rysunki wymiarowe

WindFree™ Avant Black i Avant S2 – jednostka wewnętrzna

AR70F07C1AWNEU, AR70F09C1AWNEU, AR70F12C1AWNEU, AR70F15C1AWNEU, AR70F07C1ABNEU, AR70F09C1ABNEU, AR70F12C1ABNEU

Jednostki: mm [cale]

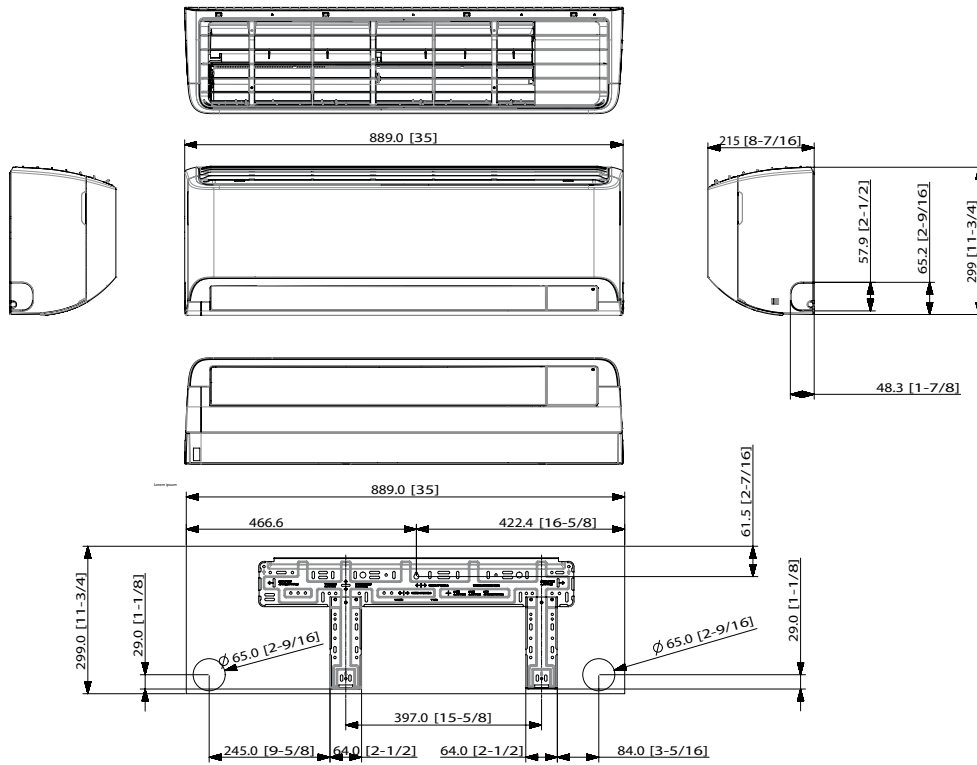

AR70F18/24C1AWNEU

Jednostki: mm [cale]

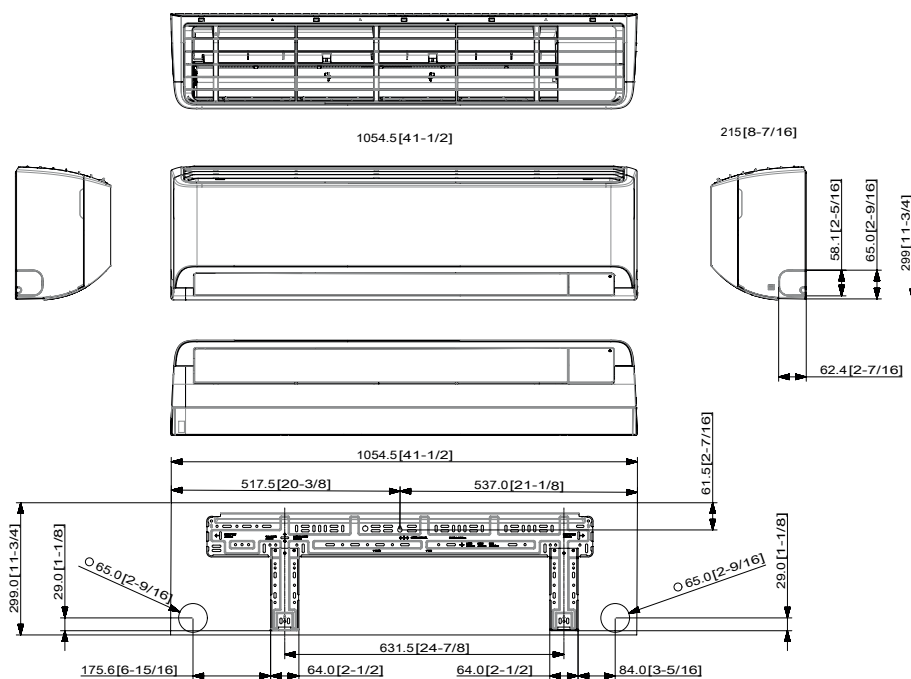

WindFree™ Avant Black & Avant S2 – jednostka zewnętrzna

AR70F07C1AWXEU, AR70F09C1AWXEU, AR70F12C1AWXEU, AR70F15C1AWXEU

Jednostki: mm [cal]

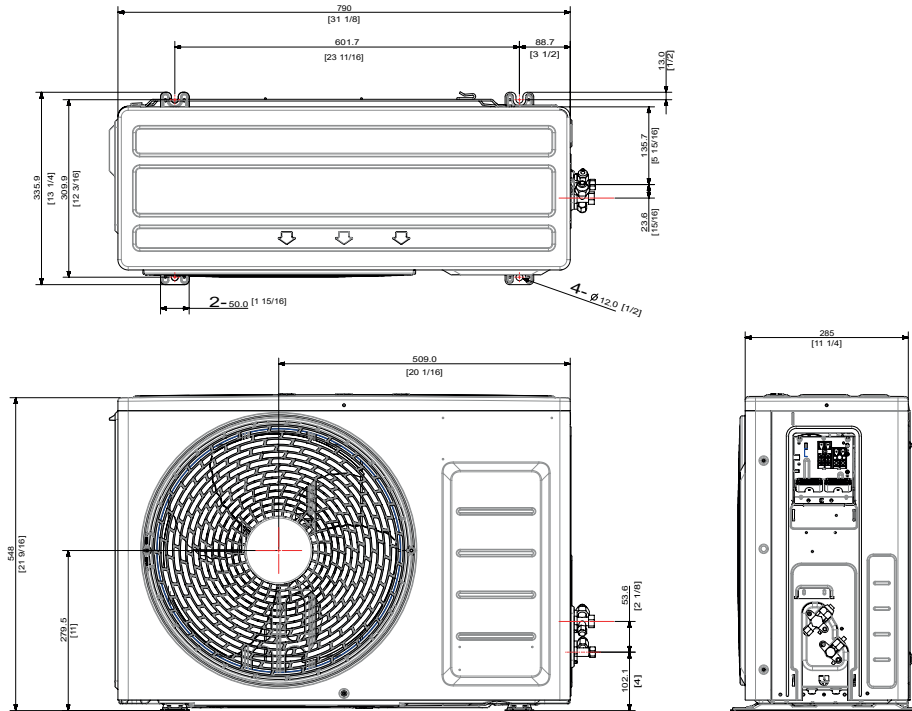

AR70F18/24C1AWXEU

Jednostki: mm [cal]

